

BOSCH

Invented for life

GBS 2036 LSN Passive Glass Break Detector



- ▶ Glass break detector in LSN technology
- ▶ For connecting to an LSN intrusion control panel
- ▶ Alarm transmission via LSN bus
- ▶ Can be used for LSN perimeter protection

The passive glass break detector in LSN technology monitors level glass surfaces within a max. 2 m radius.

Functions

Passive glass break detectors are glued directly onto glass plates in windows and doors.

The mechanical vibrations that occur when the glass is damaged are measured and analyzed.

Scratches on the glass plate made by a glass cutter are not recognized as glass break.

The analysis is carried out via the LSN intrusion control panel.

Certifications and Approvals

Coun- try	Certification	GBS 2036 LSN
DE	VdS	G 101502, B

Installation/Configuration Notes

Functional tests can be conducted using a detector testing device. Alarm triggering is displayed at the control panel and also directly indicated on the detector.

Notes on installation

The GBS 2036 LSN passive glass break detector is glued to level glass plates in rooms.

If several glass break detectors are grouped together in a detector zone, each group must be limited to 20 glass break detectors.

The glass break detector should preferably be installed horizontally, at a minimum distance of 5 mm from the window frame, and at least 20 mm from the long side.

The side of the glass to which the detector is attached may not have other material attached to it (e.g. anti-splinter foil, transparencies, etc.) nor may it be painted.

The plates to be monitored must not be damaged (e.g. splintered) and must be firmly fixed in frames. Plates that can be easily removed from the outside should be additionally monitored against removal.

Plates of glass in premises in which air containing chlorine or other aggressive substances is present (e.g. swimming pools) are unsuitable for installation.

Installation of a glass break detector on a plate

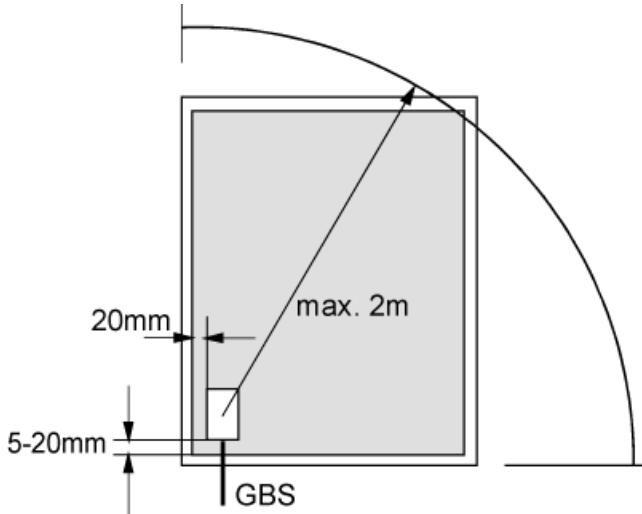

Installation distance from frames: 20 mm

Installation of multiple glass break detectors on one plate

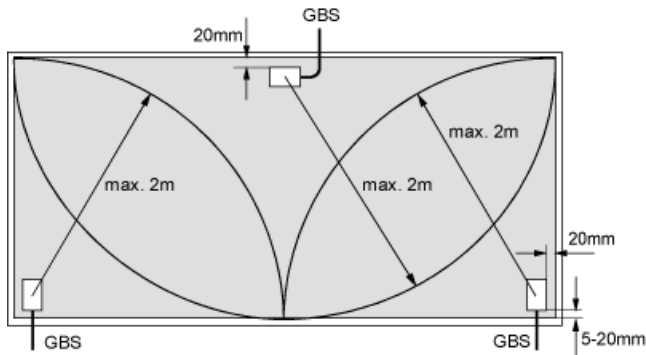

Installation distance from frames: 20 mm

The detector cannot be used for the following types of plates:

- Pyrostop glass (fire-retardant)
- Structured glass
- Plates made of plastic material
- Glass bricks
- Compound layer glass
- Armored (wire insert) glass

Technical Specifications

LSN operating voltage	15 V to 33 V
Current consumption	0.56 mA
Protective system	IP 67
VdS environmental class	III
Permissible ambient temperature	-25°C to +70°C

Housing

- Material: S-B
- Color: White

Dimensions

- Device (W x H x D): 19 x 37 x 12 mm
- Connection cable: Ø 3.2 mm, 4 m long

Ordering Information

GBS 2036 LSN Passive Glass Break Detector	4998014173
---	------------

Parts Included

Type	Qty.	Component
GBS 2036 LSN	1	Passive glass break detector

Europe, Middle East, Africa:
Bosch Security Systems B.V.
P.O. Box 80002
5600 JB Eindhoven, The Netherlands
Phone: +31 40 2577 284
Fax: +31 40 2577 330
emea.securitysystems@bosch.com
www.boschsecurity.com

Americas:
Bosch Security Systems, Inc.
130 Perinton Parkway
Fairport, New York, 14450, USA
Phone: +1 800 289 0096
Fax: +1 585 223 9180
security.sales@us.bosch.com
www.boschsecurity.us

Asia-Pacific:
Bosch Security Systems Pte Ltd
38C Jalan Pemimpin
Singapore 577180
Phone: +65 6319 3450
Fax: +65 6319 3499
apr.securitysystems@bosch.com
www.boschsecurity.com

Represented by